



Installation and User Manual



LOGG A N

Dear Customer

Thank you for purchasing LOGAN cast iron solid fuel boiler. This instruction manual is intended to help you install and operate the product safely, properly and economically. Please read this manual carefully before installation and operation of your product, and keep it during the whole operation life. Do not touch or interfere any part of the product other than those allowed. The installation, maintenance and service of this boiler requires skilled technicians. For the installation of the boiler and proper room selection, installation of water circuit, chimney design, this manual and mandatory regulations must be considered.

Carry out maintenance and cleaning work recommended on your heating system at regular intervals. Details can be found later in the instruction manual. By doing this, you will not only be ensuring the operational reliability of your heating system but also its efficient and low-emission operation.

DECLARATION OF CONFORMITY

No. 0113A

Type of the equipment	: Hot water boilers for solid fuel (wood) with manual fuel supply EN 303/5:2013
Trademark	: Thermasis
Type designations	: LOGAN 3 LOGAN 4 / LOGAN 4F LOGAN 5 / LOGAN 5F LOGAN 6 / LOGAN 6F LOGAN 7 / LOGAN 7F LOGAN 8 / LOGAN 8F LOGAN 9 / LOGAN 9F LOGAN 10 / LOGAN 10F
Manufacturer	: BOYSIS MAKINE TAAHHUT SANAYI ve TICARET A.Ş. Şerifali Mahallesi Hüsrev Sokak No.2 Erişkenler Plaza Kat 3, 34775, Istanbul/TURKIYE

The following harmonised standards or regulations which comply with good engineering practice in safety matters in force within the EU have been applied:

EN 303/5 : 2013
EN 60335-1 : 2012
EN 60335-2-102 : 2016
2014 / 68 / EU
2015 / 1187 / EU

As manufacture and/or authorised representative within EU, we declare under our sole responsibility that the equipments follow the essential requirements foreseen by the above mentioned regulations

Signed for and on behalf of the manufacturer by:

Murat Gedik [Sales Consultant]
Bursa, May 4th, 2020



1 INTRODUCTION AND DELIVERY

Logan is a cast iron boiler for solid fuels which is constructed in advanced three pass horizontal flue gas circulation principle. It is designed for hot water heating systems, therefore should not be used for direct sanitary water supply. Logan fires your fuel with very high water efficiency, saving on your fuel cost. As the bottom grate of the boiler is water cooled, the boiler can maintain sufficient outlet water temperatures until all fuel in the combustion chamber is consumed.

Your boiler can be used either in forced or natural water circulation systems thanks to its large waterways inside the boiler and medium sized delivery and return connections. You can fire different solid fuels whose specifications are given further in this manual. As calorific values of solid fuel types differ from each other, the output power of the boiler will vary between a maximum and a minimum range specified.

Delivery term: Logan is delivered in two packages

1. Boiler body, secured on a wooden pallet
2. Accessories in a cardboard box (external cabinet, insulation material, regulating thermostat, thermometer, cleaning brush, fuel shaker arm, and this manual)

Optional accessory: A safety heat exchanger kit against overheating should be purchased. This kit holds a copper heat exchanger against excessive heat accumulation inside the boiler, a safety valve to activate the heating system at high water temperatures, and auxiliary accessories for installation. Whether the hydraulic circuit is open vented or pressurised, this safety heat exchanger system should be utilized for meeting the regulations of related European standard for this product, as well as safety of whole heating installation and boiler itself.

2 SAFETY WARNINGS

2.1 Basic safety instructions

- Never get yourself into danger; give own safety the utmost priority.
- Keep children away from the boiler room and fuel storage room.
- Observe all instructions related to operation, maintenance, servicing and cleaning.
- Heating system and boiler should only be installed and started up for the first time by an authorised installer. Professional installation and start-up are essential for safe and economical operation.
- Never make any changes to the heating system or flue gas system.
- Never close or remove safety valves.

2.2 Warning signs

DANGER - Risk of poisoning
<ul style="list-style-type: none">• Make sure that the boiler is supplied with sufficient combustion air. The openings in the combustion air inlet must never be partially or completely closed.• Ventilation systems, central vacuum cleaning systems, extractor fans, air conditioning systems, flue gas blowers, dryers or similar equipment must never be allowed to draw air from the boiler room• The boiler must be connected tight to the chimney using a flue gas tube.• Clean the chimney and the flue gas tube at regular intervals.• Boiler room must be sufficiently supplied with air and ventilated.

DANGER - Risk of electric shock

- Switch off any component on the system before performing work on the boiler.
- ALL ELECTRICAL APPLIANCES ON HEATING SYSTEM MUST BE EARTHED !

DANGER - Risk of explosion

- Never burn petrol, diesel, engine oil or other explosive materials in the boiler or storage room
- Never use liquids or chemicals to ignite the fuel
- Switch off the heating system before any work on boiler or heating system

DANGER - Risk of fire

- Do not store any flammable materials in the boiler room.
- Do not hang out any washing in the boiler room.
- Always keep all boiler doors closed during operation
- Store fuels in another room, or leave a minimum distance of 80 cm between boiler and fuel pile.

WARNING - Risk of burns

- Do not touch the flue spigot or the flue gas tube.
- Do not touch boiler hot surfaces (front upper and front door when boiler is hot. Use only door handles. Use gloves for performing all work and fuel loading
- Do not open ash door reach into the ash chamber.
- Do not clean the boiler until it has been allowed to cool down.

NOTICE

Damage to property

- Do not feed cold water directly to the boiler overheated by any reason. This may result in noise production in the system and/or permanent damage on boiler body.
- Do not drain water in hydraulic circuit unless in case of maintenance or risk of freezing
- Heat the boiler using fuels that comply with the specifications below
- Do not use the heating system if it, or any of its components, come into contact with water.
- If any damage occurs, have the heating system checked by your authorised service staff or approved technicians, and have any damaged parts replaced in case needed.

2.3. What to do in an emergency

What to do in the event of a fire

- Switch off the heating system.
- Call the fire brigade
- Use approved fire extinguishers.

What to do if you smell smoke

- Switch off the heating system.
- Close the doors leading to living areas.
- Ventilate the boiler room.

3 TECHNICAL DATA

Model		LOGAN							
Types		KL 3	KL 4	KL 5	KL 6	KL 7	KL 8	KL 9	KL 10
Description of boiler		Manually stocked, cast iron sectional boilers, for solid fuels in 3pass flue circulation principle							
Number of sections	pcs.	3	4	5	6	7	8	9	10
Output range	(Coal) kW	16-20	22-30	32-40	42-50	52-60	62-70	72-80	82-90
	(Wood) kW	14-16	18-24	26-32	34-40	42-48	50-56	60-66	70-76
	(Pellet) kW	18	26	34	42	50			
Water Content	lt	27,5	34	41	47,5	54	60,5	66,5	73
Net weight	kg	208	243	278	313	350	387	424	461
Combustion chamber dimensions									
	Height	485							
	Width	360							
	Depth	220	320	420	520	620	720	820	920
	Volume	38,4	55,9	73,3	90,8	108,3	125,7	143,2	160,6
Required draft at chimney	Pa	18-24		20-28		24-32		32-40	
	mbar	0,18-0,24		0,20-0,28		0,24-0,32		0,32-0,40	
Max. Fuel loading height (for log wood)	mm	425							
Max. Logwood length	mm	200	300	400	500	600	700	800	900
Maximum operating temperature	°C	100							
Maximum operating pressure	bar	4							
Water flow/return connections (D)	G	1 ½"							
Filling / draining connection	G	½"							
External dimensions	L	610	710	810	910	1010	1110	1210	1310
	L1	400	500	600	700	800	900	1000	1100
	Flue outlet diameter (D)	160				175			

Fuel type		Wood logs							
Maximum fuel charge	kg	12	17	22	26	31	36	41	46
Requested fuel parameters		Maximum water content 20% Maximum cross section 10 cm x 10 cm Average calorific value 17.000 - 20.000 kJ/kg							
Flue gas mass flow	g/s	9,0	13,0	18,0	21,5	26,0	31,5	36,0	40,0

Fuel type		Hard coal, lignite, coke							
Maximum fuel charge	kg	15	21	27	33	40	45	51	57
Requested fuel parameters		Maximum water content 15% Average size between 30 to 60 mm Average calorific value 26.000 - 30.000 kJ/kg							
Flue gas mass flow	g/s	13,0	20,8	26,0	31,5	37,0	43,0	48,0	54,0

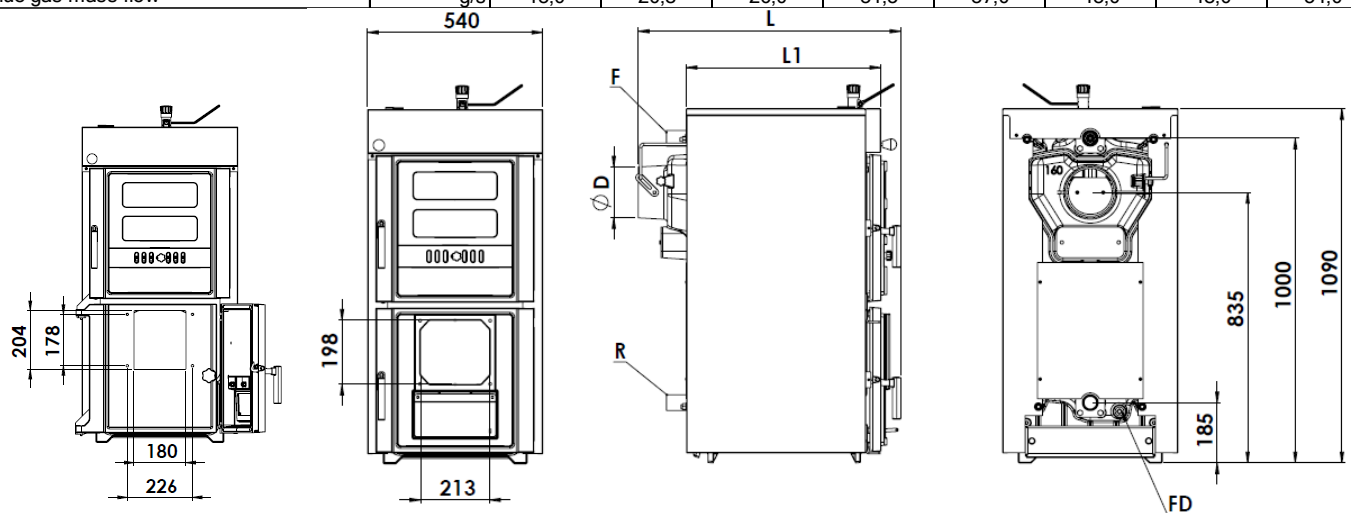

You can install a pellet burner on your boiler. For this purpose you can either use pellet burner assembly flange on boiler's front lower door, or purchase individual pellet burner door from the boiler supplier. Before any use or purchase, first check if pellet boiler you find in the market fits your boiler, see the sketch above on the left. Maximum burner tube diameter you can fit on this boiler is 180 mm. Burner must be installed and operated in accordance with burner manufacturer's regulations. Any misuse will terminate all warranty terms given by boiler manufacturer

4 BEFORE INSTALLATION

4.1. Handling the product

Logan is a heavy product, and care should be taken when carrying the boiler to the room where it is going to be installed. The total weight of each boiler is indicated in Technical data section. Carrying equipments must be of enough capacity to support that weight.

4.2. Room selection

Logan boiler must be installed in an individual boiler room particularly organized for heating. The boiler room should be of enough volume for installation, firing, and maintenance of the boiler. There should be enough fresh air circulation for combustion, the chimney design must ensure an adequate draught for related boiler type, and must comply with construction criteria given further in this manual and in mandatory regulations. Your boiler must never be installed in open spaces or balconies, in spaces occupied by people like kitchen, living room, bathroom, bedroom, in spaces where there are explosive and combustible materials.

The boiler room should have air ventilation holes through outside to let fresh air in. One air ventilation hole must be built maximum 40 cm below the level of room ceiling, the other must be built maximum 50 cm above the floor level. These ventilation holes should always be kept open. The upper hole should be at least 40x40 cm in size, the lower hole at least 30x30 cm.

All hydraulic and electrical circuits must be arranged by authorized staff in accordance with mandatory regulations specified by legal organizations. Solid fuels should be stored by keeping minimum 800 mm distance from the boiler. We recommend you to keep the solid fuel in another room.

Boiler should be installed on a concrete plinth made of a fireproof material. For minimum sizes of the plinth following table should be referred

Model	KL 3	KL 4	KL 5	KL 6	KL 7	KL 8	KL 9	KL 10
Plinth height (mm)	50							
Plinth width (mm)	520							
Plinth length (mm)	400	500	600	700	800	900	1000	1100

4.3. Clearances around boiler

At least the following clearances should be achieved around the boiler:

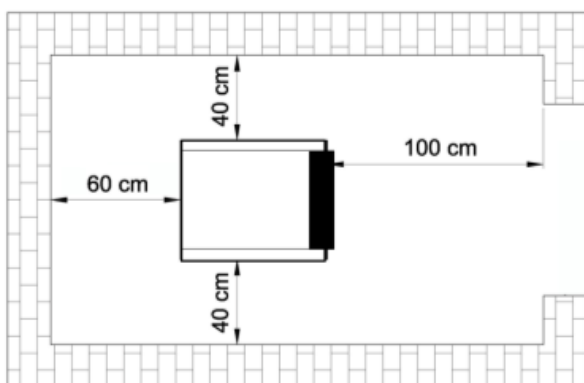

5 INSTALLATION

5.1. Circulation pump

We recommend building a forced water circulation system accompanied with a sufficient pump. Refer to the system diagrams given further in this manual to find the right position of the pump within the hydraulic circuit.

NOTICE

- Your boiler does not switch the pump on and off automatically. That is why, you should keep the pump switched on, when the boiler temperature is above the cold water temperature or there is flame inside the combustion chamber. Never switch the pump off unless the fire is completely off.
- Never let the boiler water temperature reach high values sharply with leaving the pump switched off. In that case, very high thermal energy of return water to boiler could result in permanent damage.

5.2. Open vented hydraulic circuit

Logan boilers are preferred to be installed in a hydraulic circuit with an open type expansion tank in accordance with the following schemes. The circulation pump may be installed on either delivery or return line of the boiler

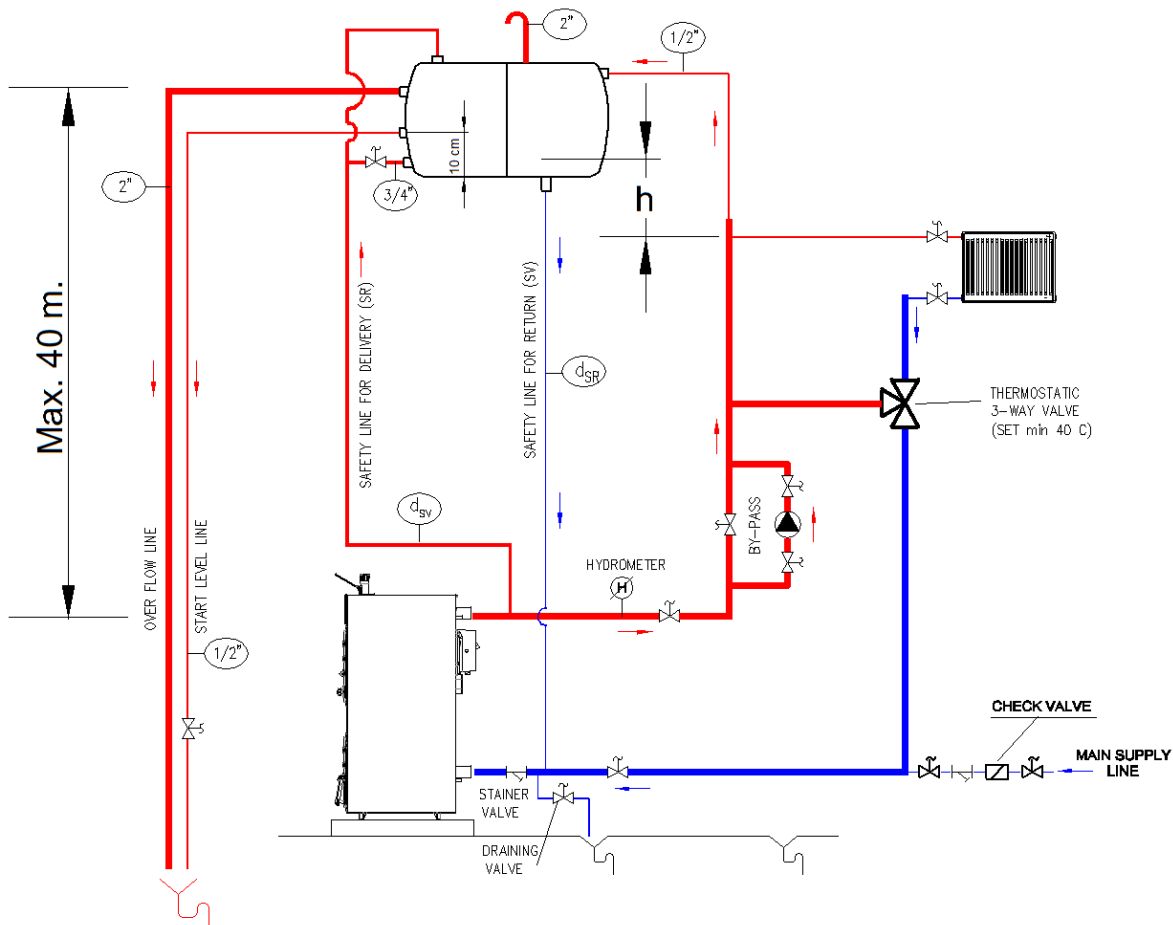

Open type expansion tank must be installed at the highest level of whole hydraulic system. No globe valves must be installed on delivery and return safety lines between boiler and expansion tank. Safety lines should be attached to inlet and outlet lines of boiler at points as close as possible to boiler, using the shortest possible

vertical way between expansion tank and boiler. If the circulation pump is installed on return line, and the head of pump at maximum speed is "h", the vertical distance (h) given in above scheme must be achieved within the system design (h, being the vertical distance between the top radiator of the circuit and bottom level of open expansion tank). If h is not achieved in such system, there will be air suction on radiators at highest level of circuit. In this case, the pump must be installed on delivery line from boiler.

A hydrometer must be installed on the delivery line to monitor the pressure level and to check if there is any leakage. The hydrometer should be purchased separately, and should be installed at the same level with the boiler outlet. A by-pass line should be installed between inlet and outlet connections of circulation pump in order to allow maximum water delivery when circulation pump is switched off and there is fuel fired in boiler, particularly during sudden electricity cuts off.

NOTICE

- The optional safety heat exchanger kit is highly recommended to be used with the boiler, even in the case of open vented systems to protect the boiler and the whole heating circuit against excessive heat accumulation. For installation of this kit, please refer to the next section.

NOTICE

- When water temperature in hydraulic circuit is relatively low, particularly when solid fuel is just fired, it is normal for water vapour in flue gases to condense. Condensation rarely creates a problem for the boiler, as it will stop when boiler becomes hot. However, the boiler should not be operated in fully condensing mode. When you open loading door, if chamber walls are wet, it means that there is condensation in flue gases. Continuous condensation does not only create massive tarrs on combustion chamber heating surfaces, but also has little effect on boiler lifetime. We will recommend you to follow one of the following methods to control condensation rate in the boiler:
 1. You can install a thermostatic three way mixing valve between delivery and return line of the boiler as described in above circuit scheme. Here, three way valve should preferably be set to 40 °C. Then, water will by-pass directly between delivery and return of the boiler, until the return water temperature reaches up to 40 °C.
 2. You can control circulation pump by means of a thermostat that can be attached delivery or return of the boiler. If thermostat is on the return line, it should be set to 40 °C, if it is on the delivery side, set to 55 - 60 °C. As the pump will not start unless water temperature rise up to the set value, boiler warms faster, and condensation mode is minimized.

5.3. Design parameters for open expansion tank

Expansion tank protects hydraulic circuit from excessive temperatures by allowing free volume for expanding water and keeping the water pressure from exceeding the static pressure. Expansion tank may be built in rectangular prism or cylindrical shape, may be installed in horizontal or vertical position in the system. Safety lines between boiler and expansion tank should be installed by an increasing slope up to tank. Following scheme shows the maximum vertical distances between safety lines and boiler:

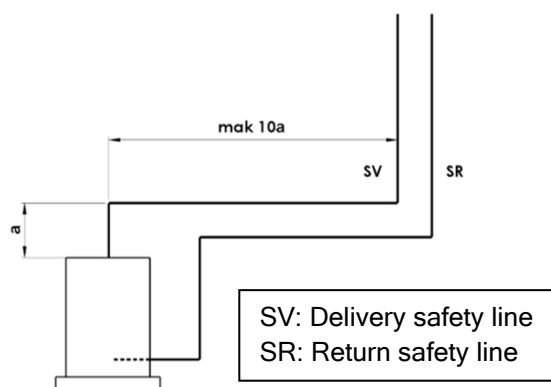

The size of expansion tank can easily be calculated regarding the total expanding water contained in whole system. If the total volume of water in the system is V_s ; the volume of expansion tank should be:

$$V_g = 8 \cdot V_s / 100 \text{ (in litres)}$$

In more practical way, just using the nominal heat output of boiler (Q_k) in terms of kW, the volume of expansion tank can be calculated as;

$$V_g = 2,15 \cdot Q_k \text{ (in litres)}$$

Size of the safety line for delivery (in mm)

$$d_{SV} = 15 + 1,5 \cdot \sqrt{Q_k}$$

Size of the safety line for return

$$d_{SR} = 15 + \sqrt{Q_k}$$

where Q_k is the boiler output in kW.

5.4. Additional safety against over-heating

To ensure safety against high temperatures on boiler and heating system, a cooling loop (safety heat exchanger) with activating valve must be installed. Safety heat exchanger includes the following items:

1. Safety heat exchanger (copper serpentine integrated with outlet stub pipe)
2. Safety valve
3. Auxiliary fittings / flexible hose

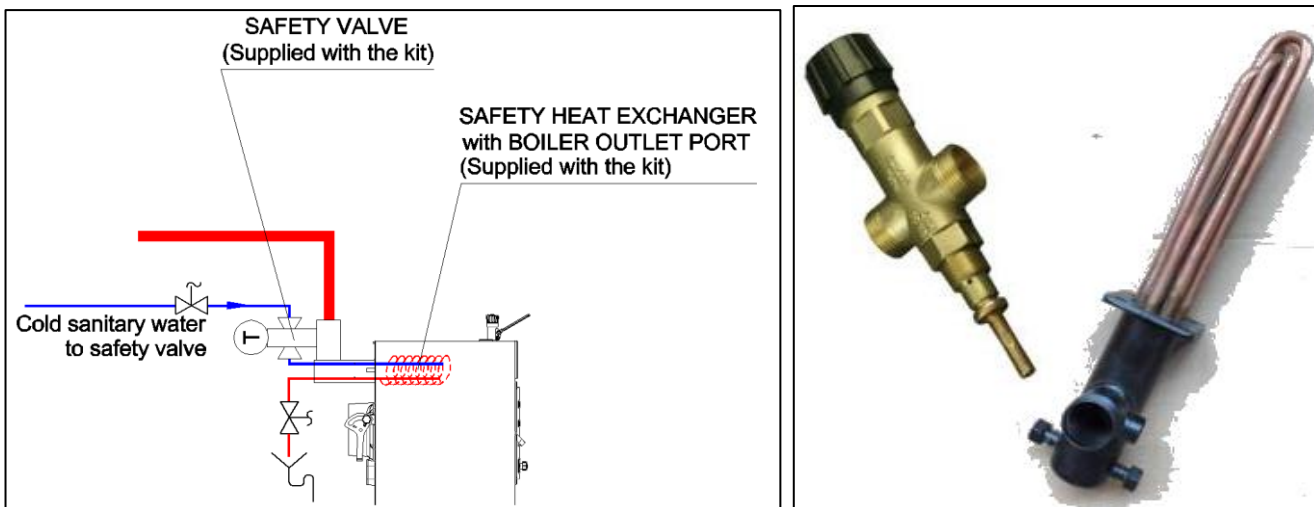

If the boiler water temperature exceeds 95 °C, thermostat of the safety valve lets cold sanitary water flows through the serpentine of the safety heat exchanger. Serpentine with cold water circulating inside cools down the boiler water temperature. When the boiler temperature decreases below the safe degree, safety valve shuts the cold sanitary water circulation, and the boiler goes back to normal operation.

NOTICE

- The valves on the sanitary connections of safety heat exchanger must always be kept open.
- Boiler can only be used with original safety heat exchanger kit which is tested and approved for each boiler model. The safety valve could be purchased separately if it is not included in the kit.
- Cold water must never be delivered directly to boiler inlet in order to solve overheating problems as this will result in serious damage on boiler body. That application will end the warranty of the boiler.

5.5. Warning on water level in system

After first water make-up in the system, minimum water level must be marked on hydrometer for open vented circuits, minimum water pressure level must be marked on manometer for pressurized circuits. Water level or pressure should be checked daily, and water should be added to circuit if they are below the minimum value. During first water make-up, oxygen must be fully discharged from the system. Generally, oxidation will not be a problem, if all measures are taken into account during first water make-up. Oxidation will take place because of fresh water addition to the system during operation of the boiler. The main reasons are as follows:

1. In open vented systems, oxygen will be added as expansion tank is open to atmosphere. That is why, open expansion tank sizes, its position in the system, safety connections to and from, are very important, and instructions given in this manual for open vented systems should be followed carefully.
2. Leak points in a system will cause oxygen to be absorbed inside the heating water. For this reason, minimum water pressure in a pressurized heating circuit must be above atmospheric pressure. Besides, pressure level should always be checked periodically.

5.6. Precautions for new installations:

System should be sized and designed accordingly, in order to minimize fresh water addition. Make sure that no part of the system is made of material that is permeable to gases. The original system filling water and any topping-up water must always be filtered (using synthetic or metal mesh filters with a filtration rating of no less than 50 microns) to prevent sludge from forming and triggering deposit induced corrosion.

5.7. Chimney connection

Your boiler must be connected to an individual chimney that will provide at least the minimum draught requested. The flue canal between the boiler and the chimney should be insulated using a glass wool material. The flue canal to chimney and chimney must be made of steel or an equivalent material that can be used at temperatures around 400 °C.

All connections on flue system must be sealed in order to perform a good combustion and efficiency. The flue canal must be connected to the chimney using the shortest way possible and in accordance with the dimensions given in the following scheme. Horizontal connections and equipments that will increase the pressure loss such as elbows should be avoided

A vertical single steel piping should not be used as a chimney. Chimney must be made of one internal and one external surface. External surface may be made of steel or brick. For internal surface stainless steel chimney elements should be preferred against corrosion. The space between internal and external surfaces of the chimney should be insulated to prevent condensation in flue gasses.

At the lowest level of chimney, there should be a cleaning cover which is made of steel, and sealed for any leakage. The length of flue canal between the boiler and the chimney should not exceed $\frac{1}{4}$ height of chimney.

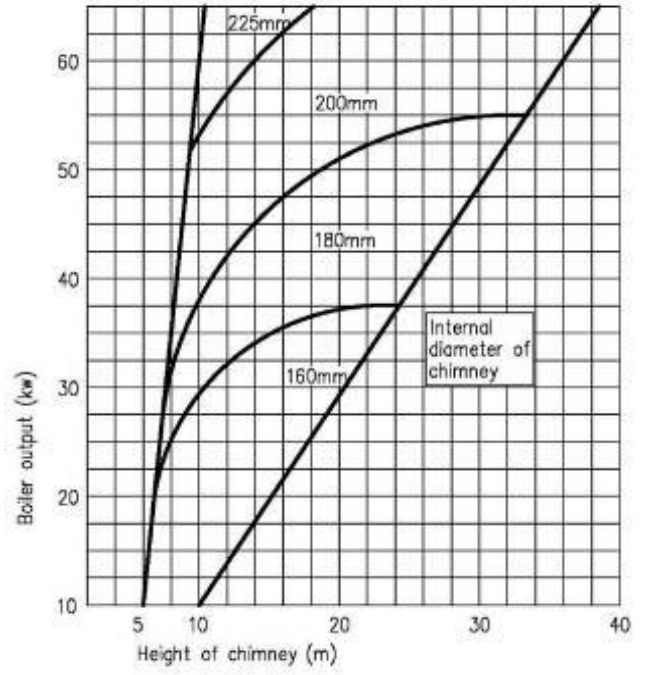
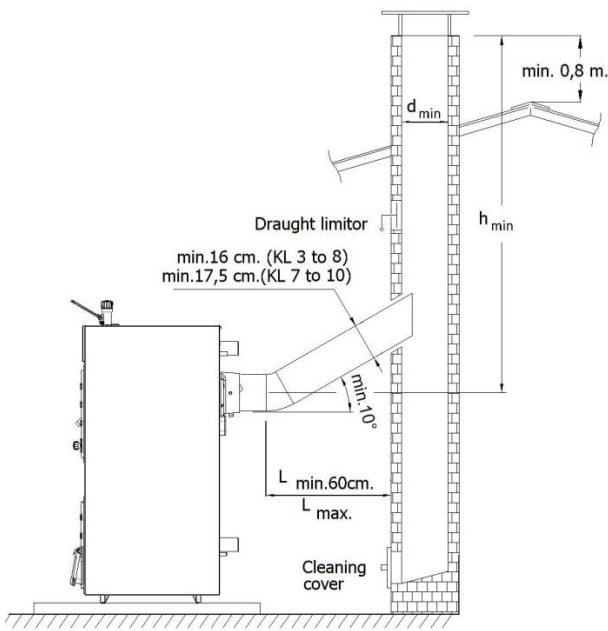

Highest level of chimney outside should be in accordance with the dimensions given in following sketch so as to minimize the harmful effect of flue gasses on ambient, and to improve draught in chimney.

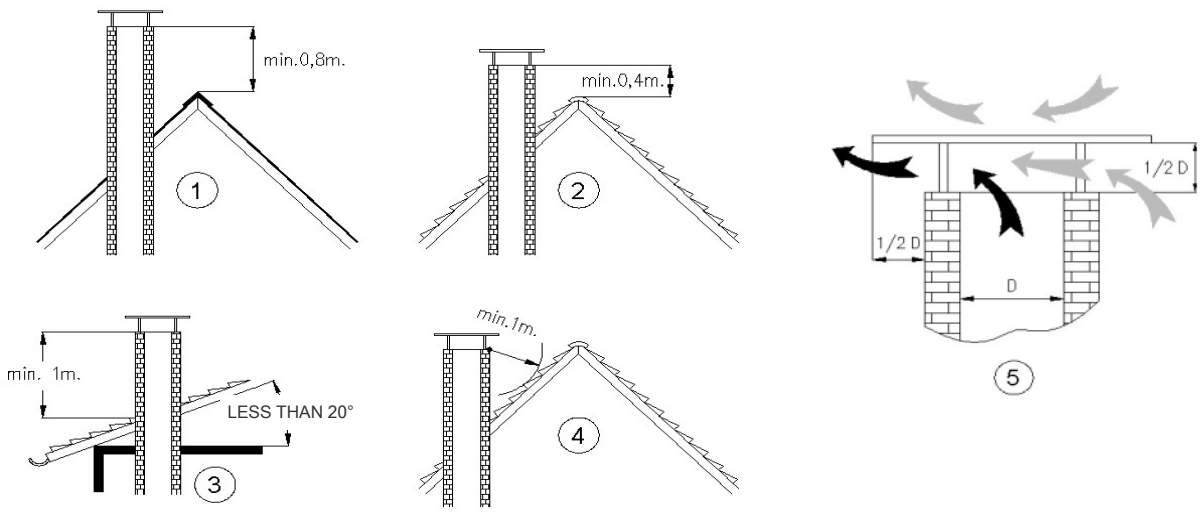

6 ASSEMBLY INSTRUCTIONS

6.1. Boiler accessories

1. Before assembly of boiler accessories, we recommend completing water inlet and outlet connections and fitting of thermostatic controller on $\frac{3}{4}$ " port on top of boiler, together with all devices on water circuit. For Logan 7 sections and above, install second controller on rear section. Then, feed the whole system with water to check any leak. Start assembly of accessories pack.

2. Loosen M10 nuts holding front door hinges a bit (in order to fit side panels)

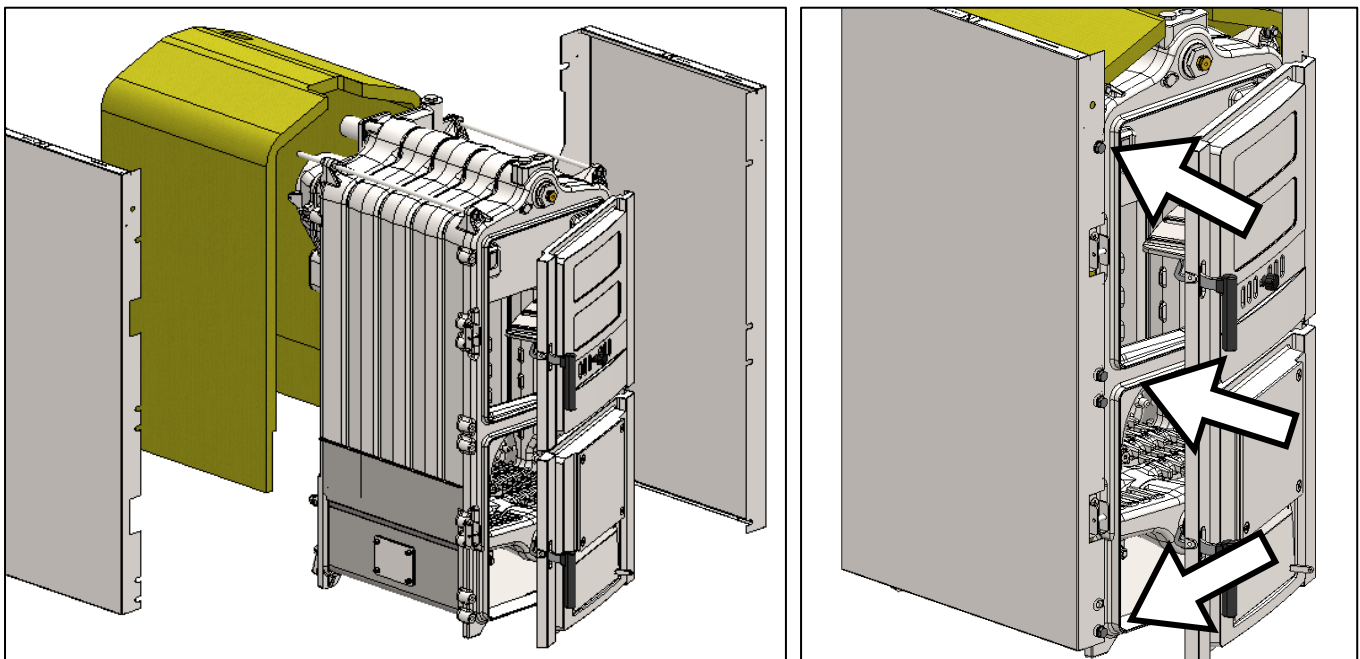
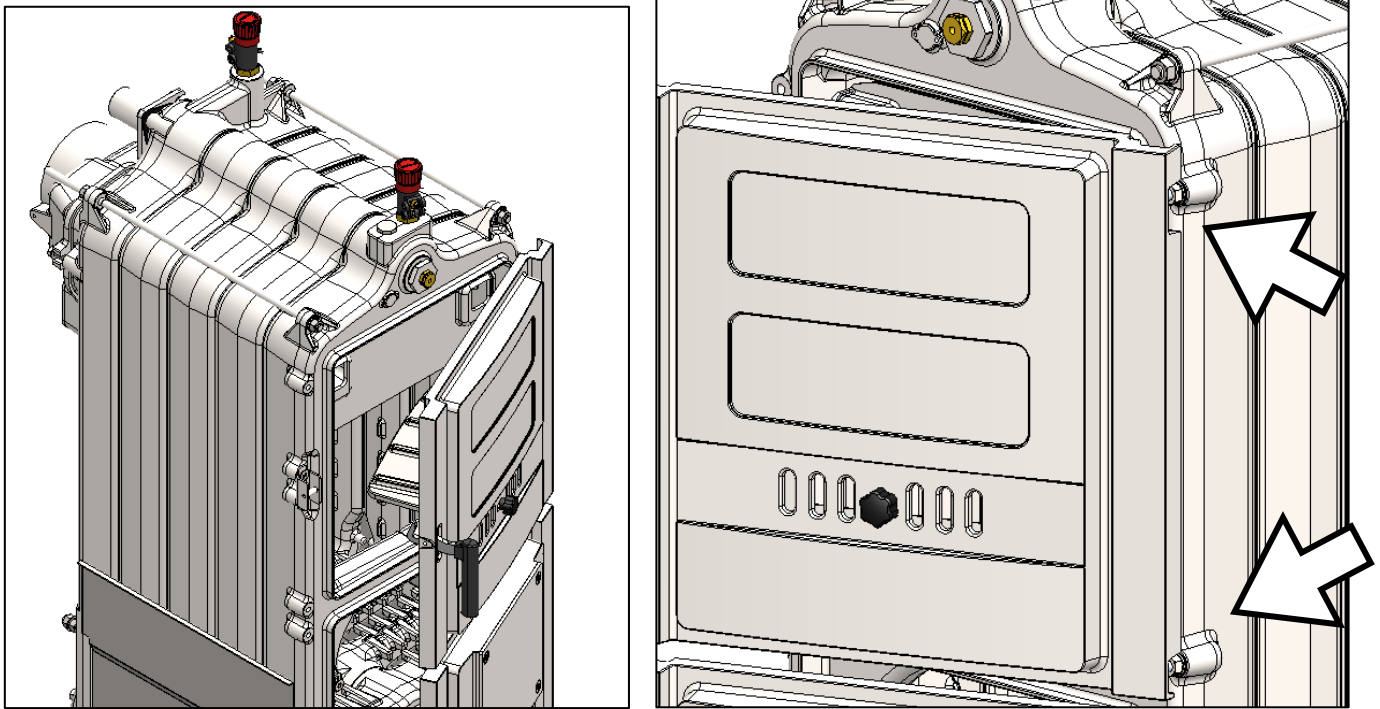

3. Put boiler body insulation squarely onto boiler body. Then fix side and left panels. On front side of boiler use four pieces M10x16 setscrews together with M10 washers for left hand side panel. For right hand panel

just tighten the existing nuts back. On rear side of boiler, put one M12 nut before, then after fitting rear bend of side panels, secure by four pieces of M12 washers and M12 nuts on each corner.

4. Fit rear insulation board, then fit rear panel with four pieces 4.2x9.5 self-tapping screws as shown below.

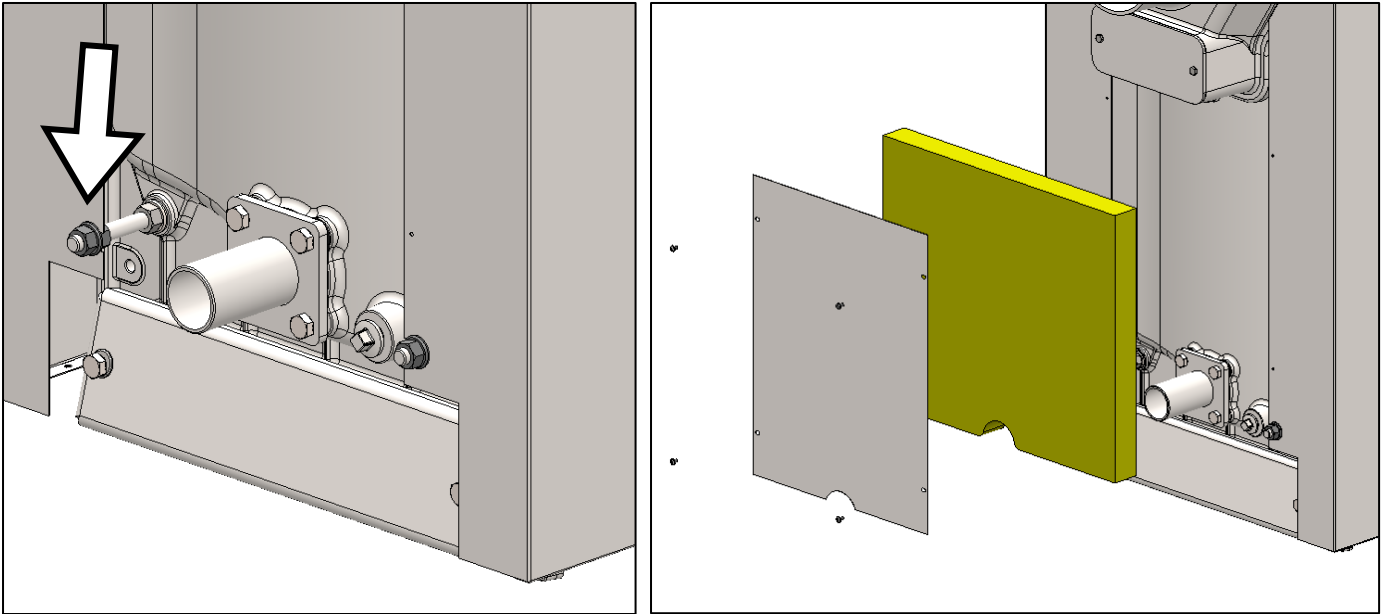

5. Make assembly of flue damper control rod. First, put rubber bearings onto the holes on front/rear bends of left hand side casing. Pass the rod through these holes

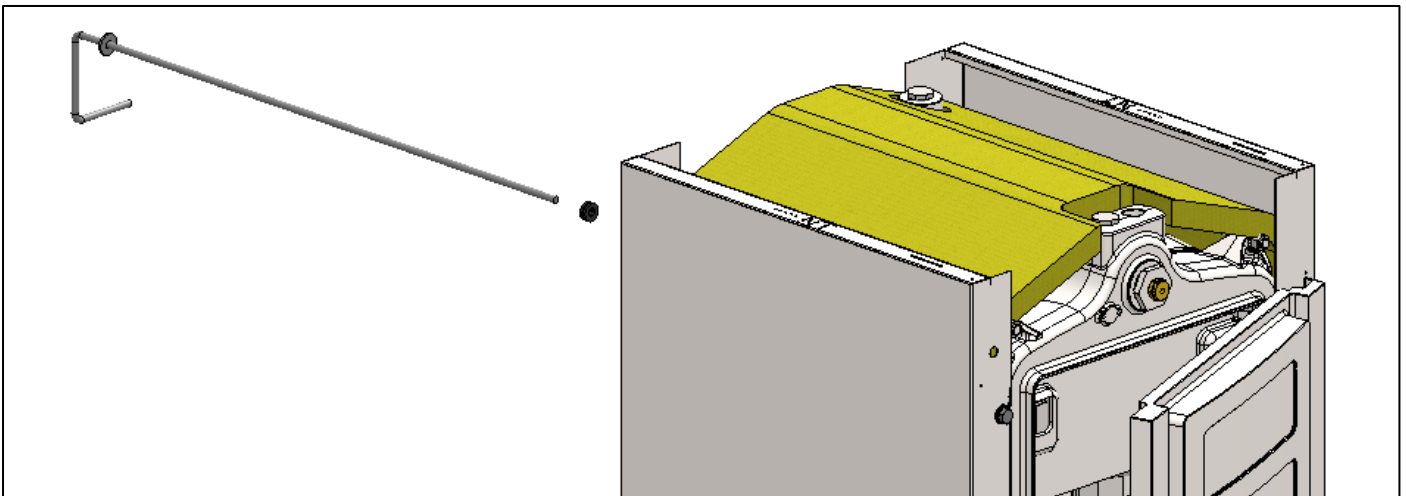

6. Fit front insulation board inside front panel, and fit front panel onto side panels securing with four pieces 4.2x9.5 self-tapping screws. Fit thermometer supplied in accessory pack onto circular port on top panel, attach its sensing element into the pocket phial on front section as shown below. Then fit top panel with four pieces 4.2x9.5 self-tapping screws.

7. Fit flue damper control knob onto the front end of damper rod.

8. Make assembly of flue damper. Pass rectangular rod that will support flue damper through the holes on smoke-hood. Then fix flue damper onto that rectangular rod by supplied setscrews. Make joint of flue damper and flue damper rod, as seen on following pictures.

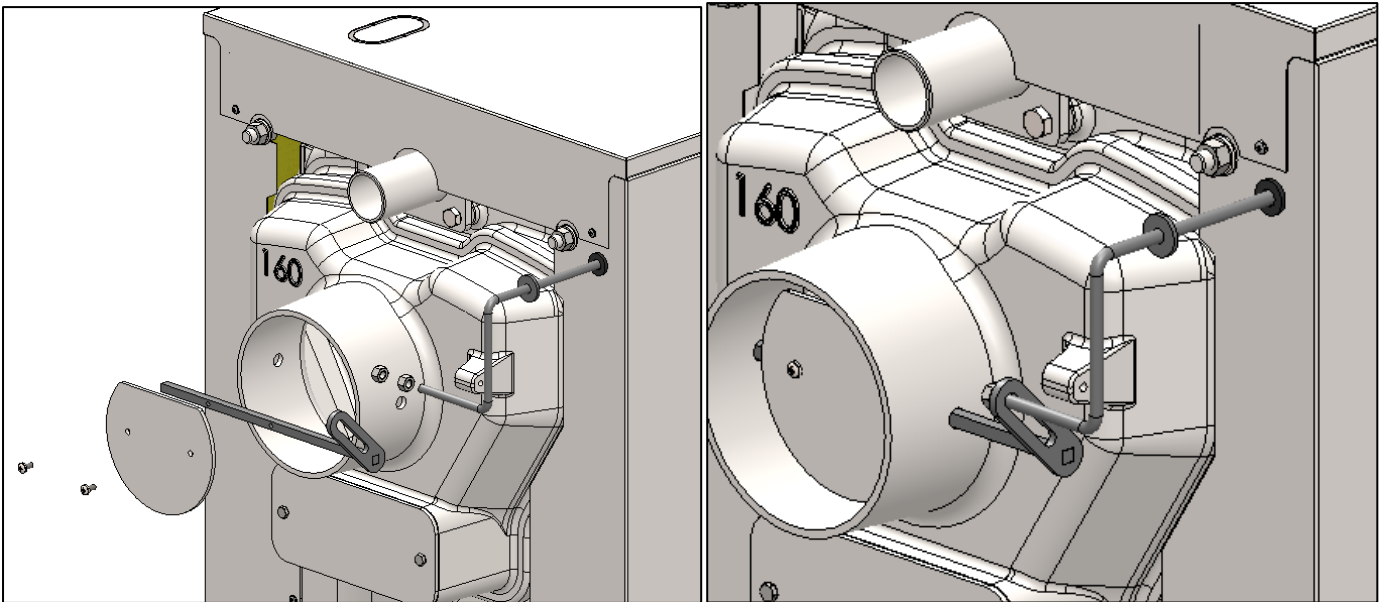
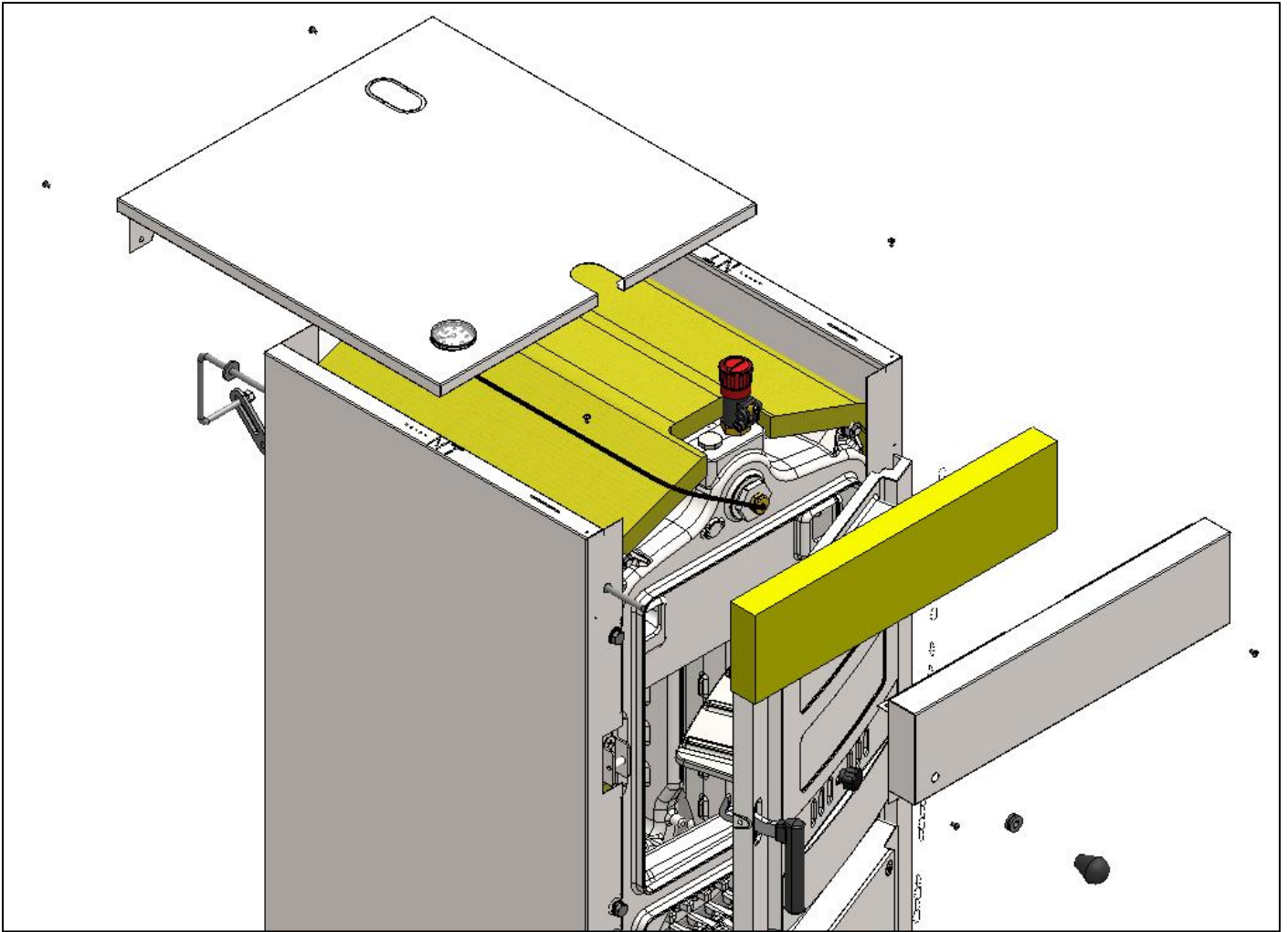

9. Fit L-shaped arm supplied with thermostatic regulator into its seating port, and secure with its original screw. Attach one end of chain on the end of arm. Attach the other end of the chain on primary air damper as shown in following pictures. Final adjustment of chain is made during first firing of boiler.

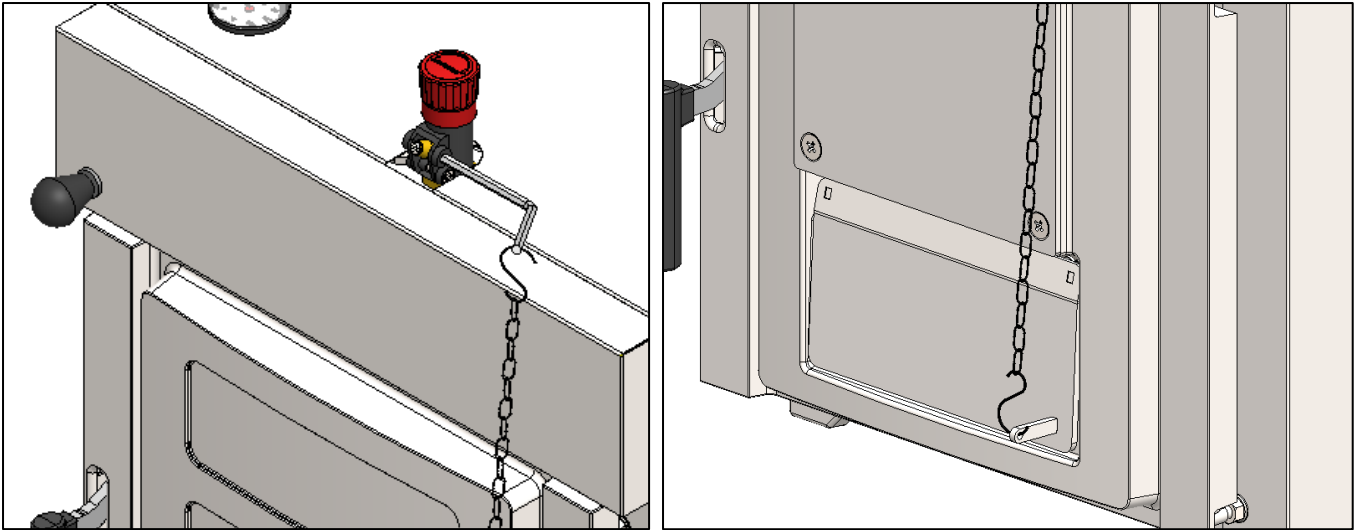

10. For second thermostatic controller on rear section, follow the same procedure in respect with above explanation and with the following pictures. Final adjustment of chain is made during first firing of boiler.

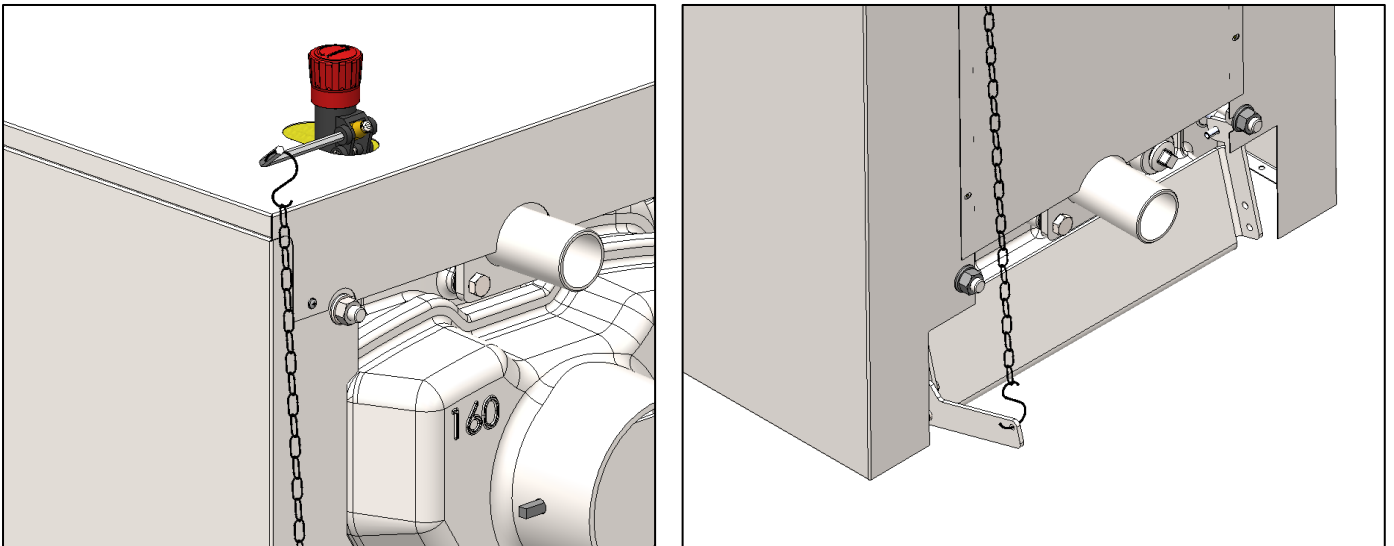

6.2. Safety exchanger

1. Remove the existing outlet piping attached to the boiler. Install safety heat exchanger to the delivery port on the rear section via 1 1/2" pipe union as shown in following pictures. Use the same flange gasket and stay bolts those you have after removing the original outlet piping.

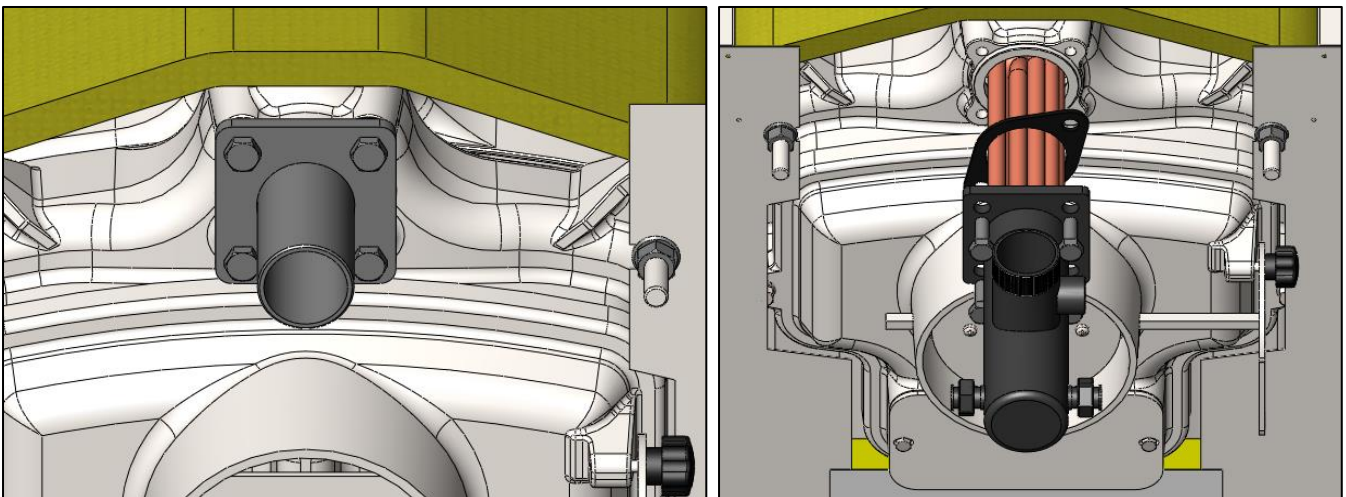

2. Attach Regulus JBV safety valve into 1/2" housing on hot water delivery line of safety heat exchanger as shown on the picture right hand side. Pay attention to the cold sanitary water flow through safety valve. This is indicated on brass body of safety valve.

3. There are two ports sized 1/2" for sanitary water inlet and outlet connection on safety heat exchanger. These ports are welded to copper serpentine of the exchanger. Attach outlet of Regulus JBV valve to one of these 1/2" ports using the flexible hose supplied within the kit.

4. Connect the cold sanitary water to inlet of Regulus JBV valve. Drain the other (hot sanitary water) outlet of the safety heat exchanger.

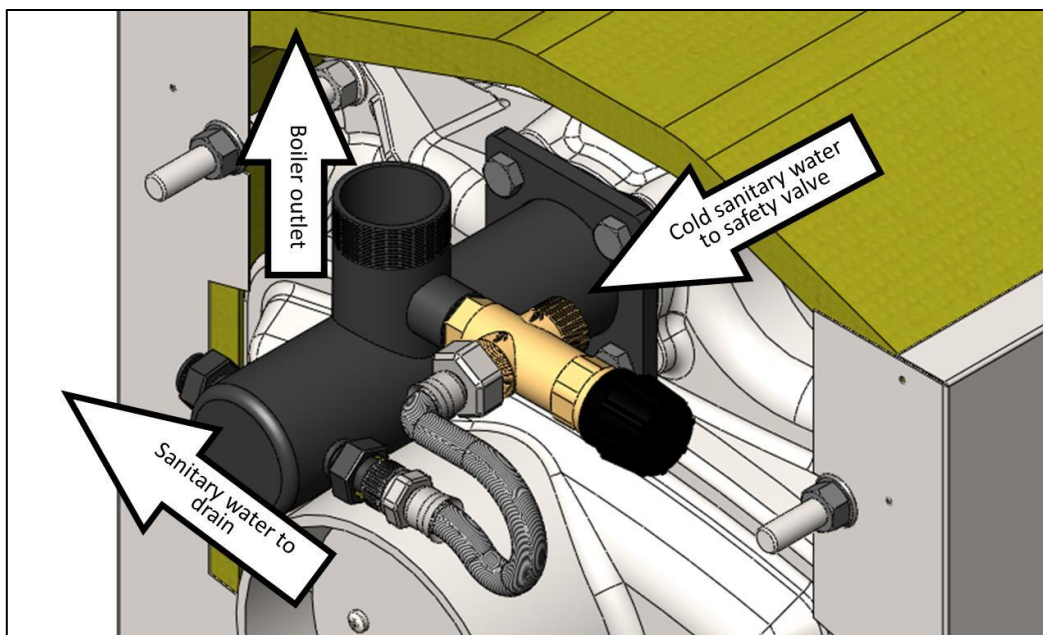
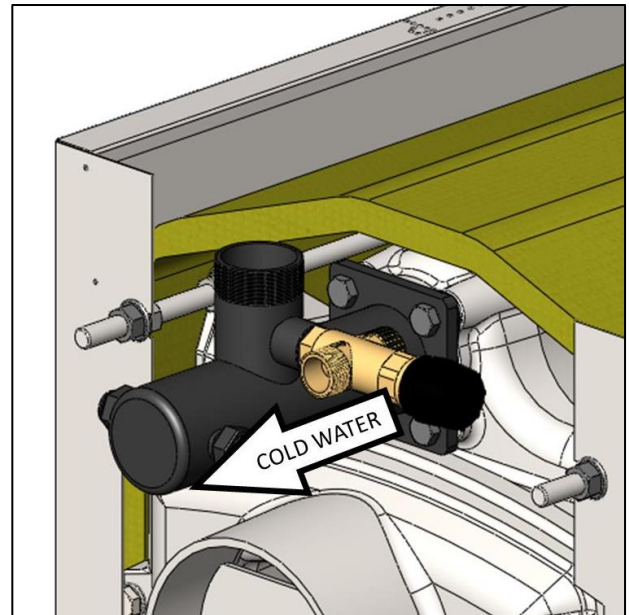

6.3. Pellet burner (optional)

Your boiler also can be operated with wood pellet fuel provided that it is used with a proper pellet burner. For more information like combustion, fuel, air inlet adjustment, refer to the burner manufacturer's manual. In order to operate the boiler with a pellet burner, you can use pellet burner opening on boiler front door or install optional pellet burner door as explained in following pictures. To use original door installed on boiler, remove burner flange, insulation board, and board protection shield, make holes for burner combustion head clearance and re-install them back.

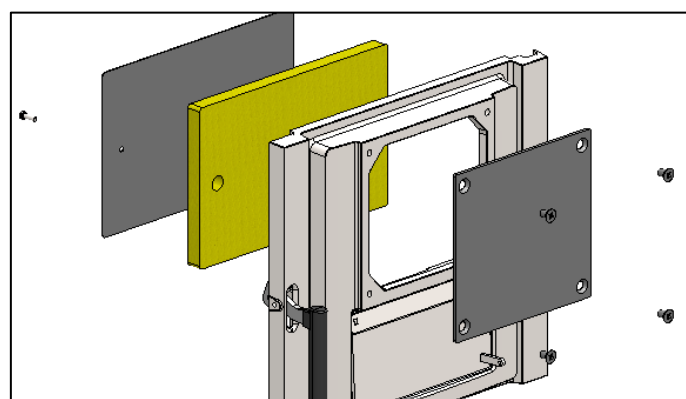

To install optional pellet door;

1- Remove the fire-door and the hinge sheet metal part. The fire door is used when the boiler is operated manual loading with wood log and coal.

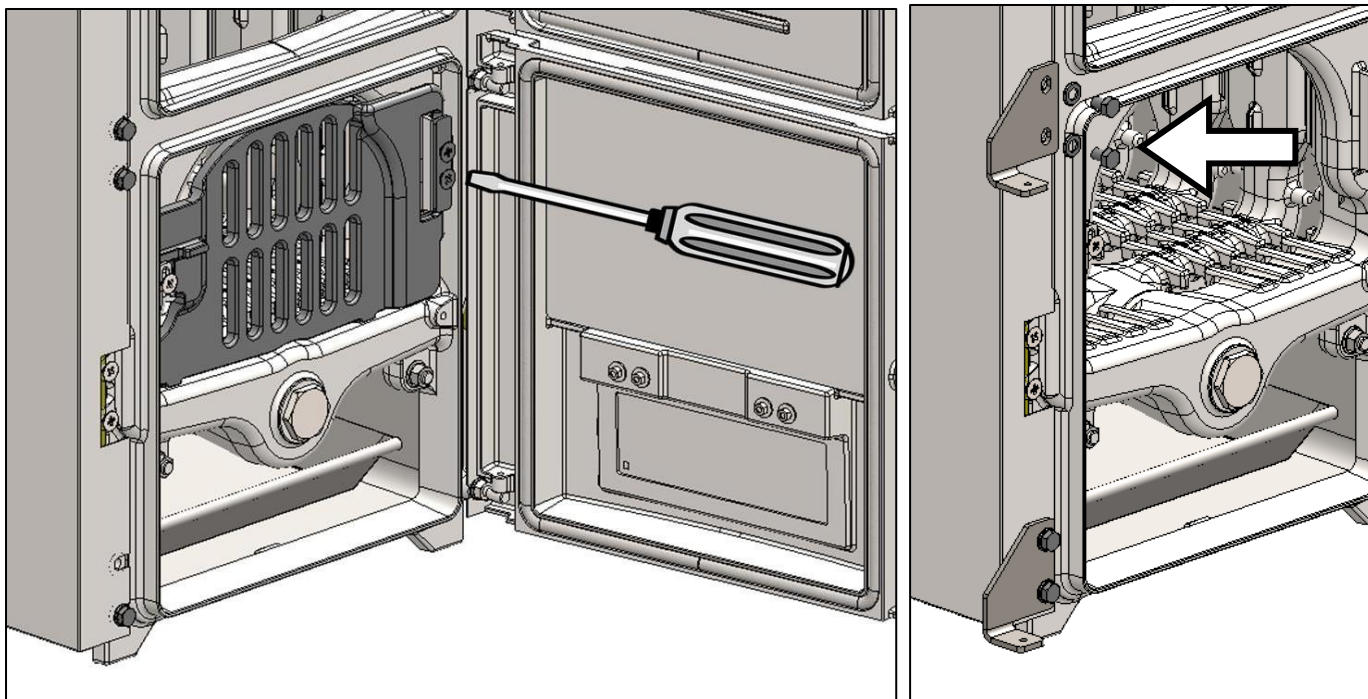

2- Remove M10 setscrews that fix left hand side panel to front section of boiler. Fit two pieces of sheet-metal parts that will support pellet burner door to boiler body with the same M10x16 setscrews. Add one setscrew from the box of pellet burner door.

3. Hang the pellet burner door using two pieces of twisted pins supplied in the pack, onto front section of boiler. Details can be seen at following pictures. Use the screwed knob and bush to close the door tightly as shown in the picture.

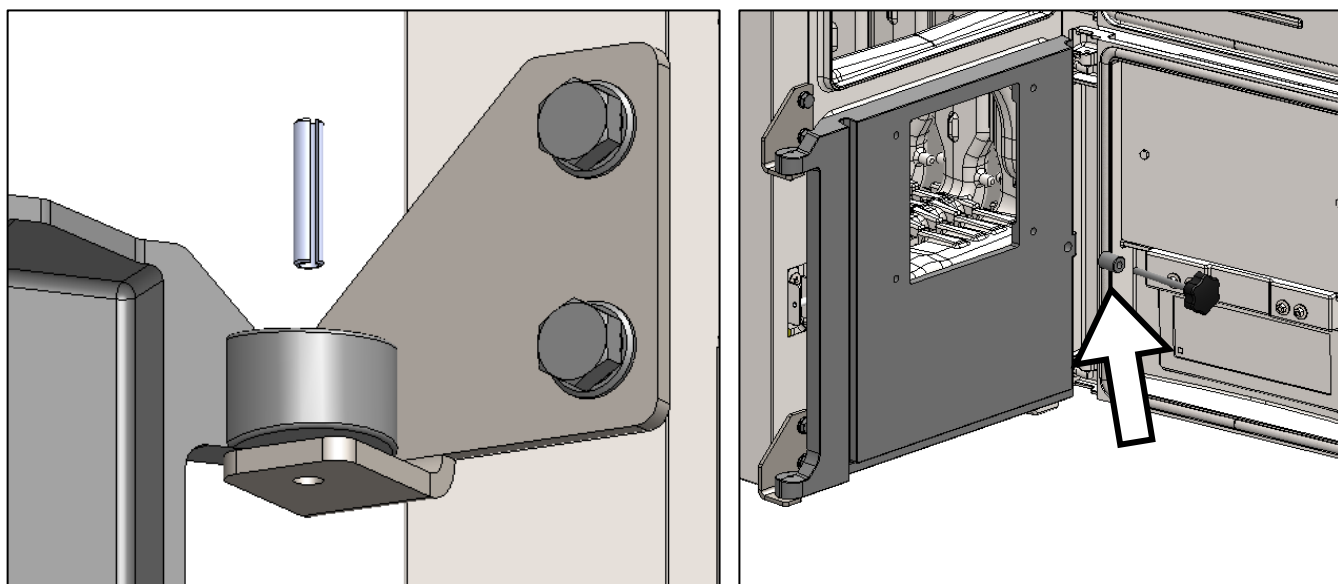

7 OPERATING INSTRUCTIONS

7.1. Setting thermo-regulator (thermostatic controller for combustion air)

Mechanic type thermo-regulator is mounted on front side of boiler in horizontal position. In horizontal operation of thermo-regulator, white coloured numbers show the requested heating temperatures. After assembly of thermo-regulator body, place the lifting rod for regulator.

Load the boiler and fire. Wait until the boiler temperature reaches 60 °C. Set the thermo-regulator to 60 °C. Attach one end of thermo-regulator chain to primary air damper. Attach the other end the chain to lifting rod of thermo-regulator, and stretch the chain, leaving 2 mm space between primary damper and air inlet of front door.

7.2. Pre-firing checks

Before first operation of boiler right after installation, hydraulic circuit must be ready for operation. To fill an open vented circuit, the valve on start level line from expansion tank is opened, and the circuit is filled with main supply water. During filling the system all valves and accessories on the lines must be checked for leakage. Filling is stopped, when water from start level line is observed, closing the valve on this line. Right after that, hydraulic pressure is marked on screen of the hydrometer. This will make re-filling operations during heating season much easier, just feeding the system with fresh water until hydraulic pressure on screen reaches the pre-marked value.

Before every firing make sure that;

1. Boiler and circuit are filled with water, and the hydraulic pressure is in the required range.
2. All valves on the line (except by-pass lines and start level line) are in open position.
3. There is enough draught in chimney.

7.3. Firing

1. Set the kindling. Place fire starters, crumpled newspaper (3 or 4 sheets balled up fairly tightly) on the grate of the boiler. Place small kindling over the paper or starter. The more dry, small kindling you have - the easier and better the fire will start. Crisscross the kindling so there is plenty of air space in between each piece. Wood that is packed too tight will not burn properly. Set larger wood on top of the kindling, and continue to set larger and larger pieces on top until the fuel exceeds the 1/3 level of the filling chamber.
2. Ensure that the primary air and chimney dampers are open. Then light the newspaper on the bottom
3. After first ignition, switch the circulation pump on, and adjust air damper. Set mechanic thermo-regulator to desired temperature as explained above
4. The fire should be well established within approximately 15 minutes, then filling chamber can be loaded completely, but check to make sure that the firefighters have not been extinguished.
5. Keep the fire going. Always keep a "flame" on your fire - a smoking or smoldering fire is a cold and inefficient fire and also produces pollutants and creosote (tar in the chimney)

7.4. Firing with wood

1. When firing wood, you can keep the secondary air damper closed in order to extend combustion period.
2. You can set flue damper on the smoke-hood at the back of boiler to positions between open and closed in order to adjust speed of combustion

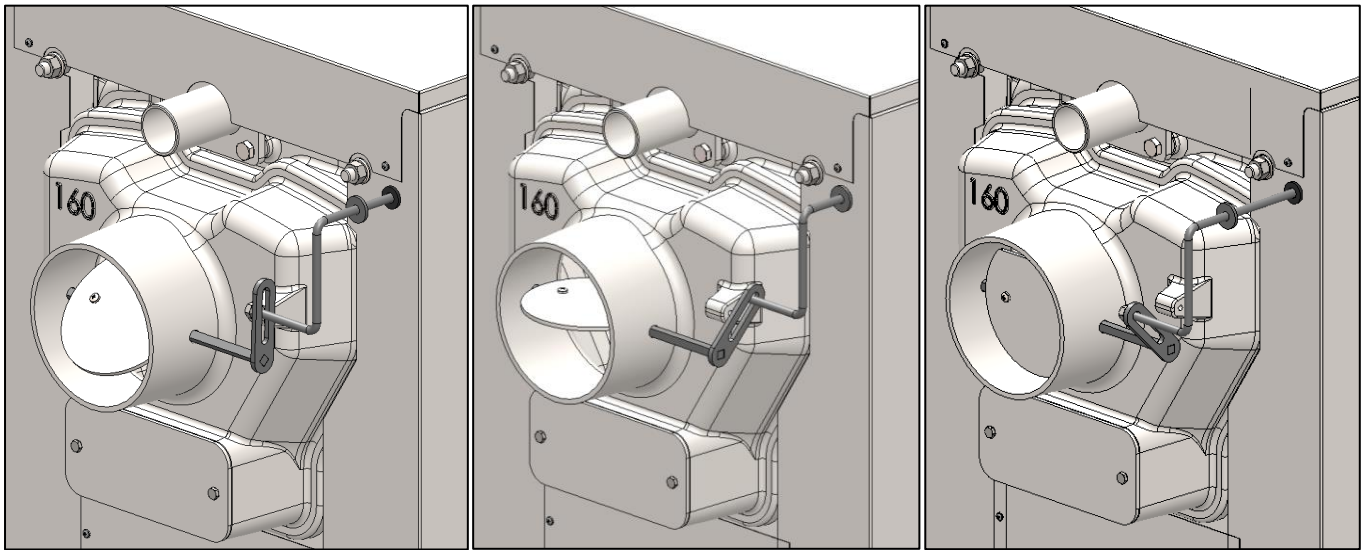

Half-open

Fully-open

Closed

7.5. Firing with brown coal and lignite

You can keep secondary air damper fully opened to achieve good combustion and better flue emissions.

7.6. Stand-by

You can slow-down the combustion by

1. Decreasing the set temperature on the thermo-regulator
2. Closing the secondary air damper fully
3. Closing the flue damper fully.

WARNING

- Your boiler does not switch pump on and off automatically. That is why, you should keep the pump switched on, when the boiler temperature is above the cold water temperature or there is fuel firing inside the combustion chamber. Never switch the pump off unless the fire is completely put off.
- Never let the boiler water temperature reach high values sharply with leaving the pump switched off. In this case, the instant cold water delivery to the very hot boiler may result in cracks on boiler body due to high thermal energy.
- If the thermo-regulator does not operate properly, shift its setting step by step according to your comfort conditions

7.7. Lack of chimney draught

If there is lack on chimney draught or there is no draught at the chimney (such as badly built, un-insulated, blocked etc.) you may face combustion problems (no fire, excessive smoke, condensation due to cold flue gasses). In this case, we strictly recommend you to have your chimney controlled by an expert, and fix any irregularity. Your boiler has been designed for natural draught principle, and that is why, chimney installation is very important.

8 HEALTH AND SAFETY INFORMATIONS

8.1. Control of substances hazardous to user health

For the type of material and where used in your boiler refer to the following chart

1. PAINTS:

General purpose black undercoat	NOT APPLICABLE
High temperature black coating	Sections Boiler body bottom plate
Powder coating	All external panels

2. INSULATION AND SEALS

Rock-wool insulation board	NOT APPLICABLE
Glass-wool insulation board (aluminium backed)	Sections Smoke-hood
Fibre-glass rope and tape	Front door
Ceramic-fibre board	Front door
CFC free polyurethane spray/foam	NOT APPLICABLE
Refractory brick	NOT APPLICABLE
Asbestos products	NOT APPLICABLE

3. SEALANTS

Red-lead dye	Nipples
Ceramic/mineral compound gasket	Flanged stub pipes
Water jointing flax	Tapings on sections
Grey paste jointing compound	Inter section joints
Fire cement	NOT APPLICABLE
Gas jointing compound	NOT APPLICABLE

NOTICE

Paints, sealants, grey paste compound, ceramic-fibre boards

1. These materials contain organic solvents and should be used in well-ventilated area away from naked flames. Do not allow to come into contact with the skin, eyes, inhale or swallow.
3. Use barrier cream or gloves to protect the skin, and goggles to protect the eyes from accidental contact.
4. Small quantities can be removed from clothes or skin with a proprietary paint remover or hand cleaning product.
5. If inhaled, remove sufferer into fresh air, if swallowed clean mouth with and drink fresh water but do not induce vomiting. If in the eye, irrigate the eye with clean water and seek medical attention.

NOTICE

Devices under pressure

1. Avoid contact with the parts of heating system under pressure during operation of the boiler. These dangerous parts are:
 - Boiler sections
 - Boiler inlet and outlet lines
 - Safety lines
 - Pressure relief devices installed on heating system
2. Never attempt to drain water from heating system when the boiler is being operated
3. Never feed the boiler directly with cold water to cool it down for any reason, when the boiler is hot.

WARNING on high temperature surfaces

Avoid contact with parts and surfaces having high temperatures (working surfaces) which will be hazardous for human such as:

1. Boiler front door
2. Fire door on the front section
3. Water delivery and return lines (even if isolated), safety lines
4. Flue spigot
5. Connection between flue outlet and chimney
6. Circulator pumps, expansion vessels

NOTICE**Flue gases**

1. There could be a little gas release from the front side of the boiler, when the front loading door is opened. Never breathe this gas flow.
2. When adding solid fuel when there is active fire bed inside the combustion chamber, protect your hands and face..If needed wear protective gloves.

NOTICE**Firing fuel**

1. Do not take the firing fuel out from the combustion chamber while it is still burning
2. Do not try to put the firing fuel off using water or any other liquids.
3. Do not leave the front doors and fire door open when there is fire inside the combustion chamber
4. To slow down or stop the fire, close air inlets, and flue outlets..
5. Your boiler can only be fired with the solid fuels whose characteristics have been given in Technical data section. Never use any other solid fuel that would be harmful for boiler section design, any liquid or gaseous fuels.

9 MAINTENANCE AND CLEANING

9.1. Periodic inspections

- * Check the water level or pressure. The hydrometer must be marked after first filling of the boiler. So water level can be checked regularly. If the water level or pressure is under the level of static pressure or the system set-up, a water make-up is needed. The make-up water should be softened according the local regulations before feeding into the system to prevent corrosion inside the heating circuit and the boiler.
- * Front doors of the boiler should be checked for properly closing. Fibre-glass ropes must be replaced if necessary. Check the condition of refractory inside the front door. If it is damaged, you will have higher surface temperatures on front doors. In this case the refractory should be replaced to save energy and prevent further crack.
- * Check if there is flue gas leakage from the chimney connections of the boiler, and have it fixed if necessary.
- * Check correct operation of thermo-regulator on top of the boiler. If needed you can slightly shift the setting of thermo-regulator for better combustion for your boiler capacity. If air is not enough for combustion, there will be excessive soot formation on heating surfaces, as well as fumes (or odours). So you should let more air re-adjusting the primary air damper setting to get richer combustion. If air is too much for combustion, solid fuel will be consumed rapidly. In this case we recommend to reduce air inlet by either primary air, or flue damper on the smoke-hood.
- * Check the heat transfer surfaces of cast iron sections. The soot formation will change according to fuel type you use, and the combustion air amount. So if you feel that the outlet water temperature cannot reach the usual values with the same conditions, heating surfaces therefore should be cleaned

9.2 Boiler cleaning

Before cleaning the boiler, switch the pump and other electrical appliances in boiler room off. To clean the boiler:

- * Clean all heating surfaces using the brush supplied with the boiler.
- * Move back deposits towards the smoke-hood if you cannot brush them forward
- * Clean the fresh air inlet section at the bottom level of intermediate sections with supplied fuel poker
- * Collect all soot deposits inside the ash tray
- * Remove the disposals collected in ash tray and rear smokehood through rear cleaning cover.

9.3. Maintenance

Before each heating season we would recommend you to call for the contracted service agent to check the boiler, heating system, electrical connections, and chimney conditions. Do not attempt to carry any maintenance work without getting help from qualified people.

START-UP / COMMISSIONING FORM

1/2

END-USER INFORMATION

NAME / SURNAME	:	_____
ADDRESS	:	_____
CITY / PROVINCE	:	_____
COUNTRY	:	_____
E-MAIL / GSM	:	_____
SIGNATURE	:	_____

PRODUCT INFORMATION

PRODUCT MODEL	:	_____
EXTRAS 1	:	_____
EXTRAS 2	:	_____
INVOICE DATE and NUMBER	:	_____
SERIAL NUMBER	:	_____

COMMISSIONING OF THE DEVICE

DATE OF COMMISSIONING	:	_____
AUTHORIZED COMPANY for COMMISSIONING	:	_____
ADDRESS	:	_____
E-MAIL / GSM	:	_____
SERVISER NAME / SURNAME	:	_____
SERVISER STAMP and SIGNATURE	:	_____

- Warranty period is 2 (two) years, and starts with signing of this document
- One copy of this document shall be handed to end-user
- General checks on next page should be completed for future reference

START-UP / COMMISSIONING FORM

2/2

General Checks	Check	Comments
Wall plug voltage measurement	_____ V (AC)	
There is no damage because of transportation		
Chimney is clean, functioning well and meets the requirements defined in manuals		
Outputs are tested before start-up and working correctly		
Plumbing plant installation is made according to manuals, and necessary sensors are installed		
Optimization for auger / chimney calibration (if needed) is made		
Purchased optional elements are installed correctly, and tested		

End-User Notification	Check	Comments
User is informed about boiler/stove cleaning and service cycles		
User is informed about errors and how to act when they are shown		
User is informed about combustion power selection and setting necessary thermostats		
User is informed about boiler/stove functioning, operating, fuel quality and warranty conditions		

REMARKS / DIFFERENCES